

Wireless LAN (MAC)



Silicon Interfaces' MAC core for Wireless LAN is compatible with 802.11 a b and g IEEE Standards. It is designed to handle packetized DSSS transmissions; the software implementation supports all Data Rates. The MAC Management or Control Functionality is implemented in hardware.

IEEE 802.11a and IEEE 802.11b and IEEE 802.11g are "High Rate" standard Wireless Local Area Network (WLAN) operating in the 2.4 GHz/5GHz unlicensed Radio Frequency (RF) band and can transmit up to 54 Mbps and 11 Mbps respectively.

This specification describes the functions and services required by an IEEE 802.11 compliant device to operate within ad hoc and infrastructure networks as well as the Station Mobility within those networks.

SI24WLAN11 is designed to use at higher speeds providing maximum performance with minimum power consumption, without draining the device batteries. It plays active role to save power when there is no frame to transmit or there is no intended frame to receive. This module also indicates about power management status to other modules. It can be used in PCs, Laptop computers, high end PDAs and other devices.

Protocol Firmware is fully compliant with SME (Station Management Entity) and MLME (MAC Sublayer Management Entity) of IEEE 802.11 Standard. It handles complete interrupt handling and event processing for the hardware.

Applications:

- Wireless Home Networking Devices
- Wireless Audio, Video, Consumer Electronics
- Wireless LAN Adapter
- Wireless LAN STA Terminal, e.g. laptop PC

Product Specifications

- ◆ Fully Synthesizable Register Transfer Level (RTL) VHDL
- ◆ Test Bench Environment: VHDL
- ◆ Targeted to Altera Excalibur EP 20K with Embedded 922T ARM Processor at 200 MIPS
- ◆ Clock - 24 MHz for FPGA (Standard: 11 MHz)

Features	802.11a	802.11b	802.11g
Data Rates	6,12,36,48,54Mbps	1,2,5.5,11Mbps	6,12,36,48,54Mbps
Frequency	5GHz	2.4GHz	2.4GHz
Security	WEP	WEP	WEP

Options:

(May be separately priced)

Add-ons:

- AMBA AHB Interface
- PHY Interface

Product Highlights

- ☑ Fully Compliant with IEEE 802.11a IEEE 802.11b and IEEE 802.11g MAC Layer Functions and Frames.
- ☑ Customize to work with all the PHY's (IEEE 802.11a, IEEE 802.11b and IEEE 802.11g)
- ☑ Supports the role of Station (STA).
- ☑ STA operates in both Infrastructures BSS as well as in Independent BSS (IBSS).
- ☑ Data rates up to 11 Mbit/sec (802.11b) and 54 Mbit/sec (802.11a and 802.11g)
- ☑ Performs CSMA/CA Algorithm to sense the medium.
- ☑ AHB Bus Interface
- ☑ Includes WEP based 64-bit Encryption/Decryption Algorithm
- ☑ Supports both Active and Passive Scanning Mode
- ☑ PHY Interface Module handles different Clock Domains between MAC and PHY
- ☑ Optimum Hardware-Software partitioning for reduced gate count as well as lower MIPS requirements
- ☑ Software configurable
- ☑ Synthesizable RTL code for Hardware Component and C- source code for MAC Firmware.

802.11 a b and g Block Representative Schematic:

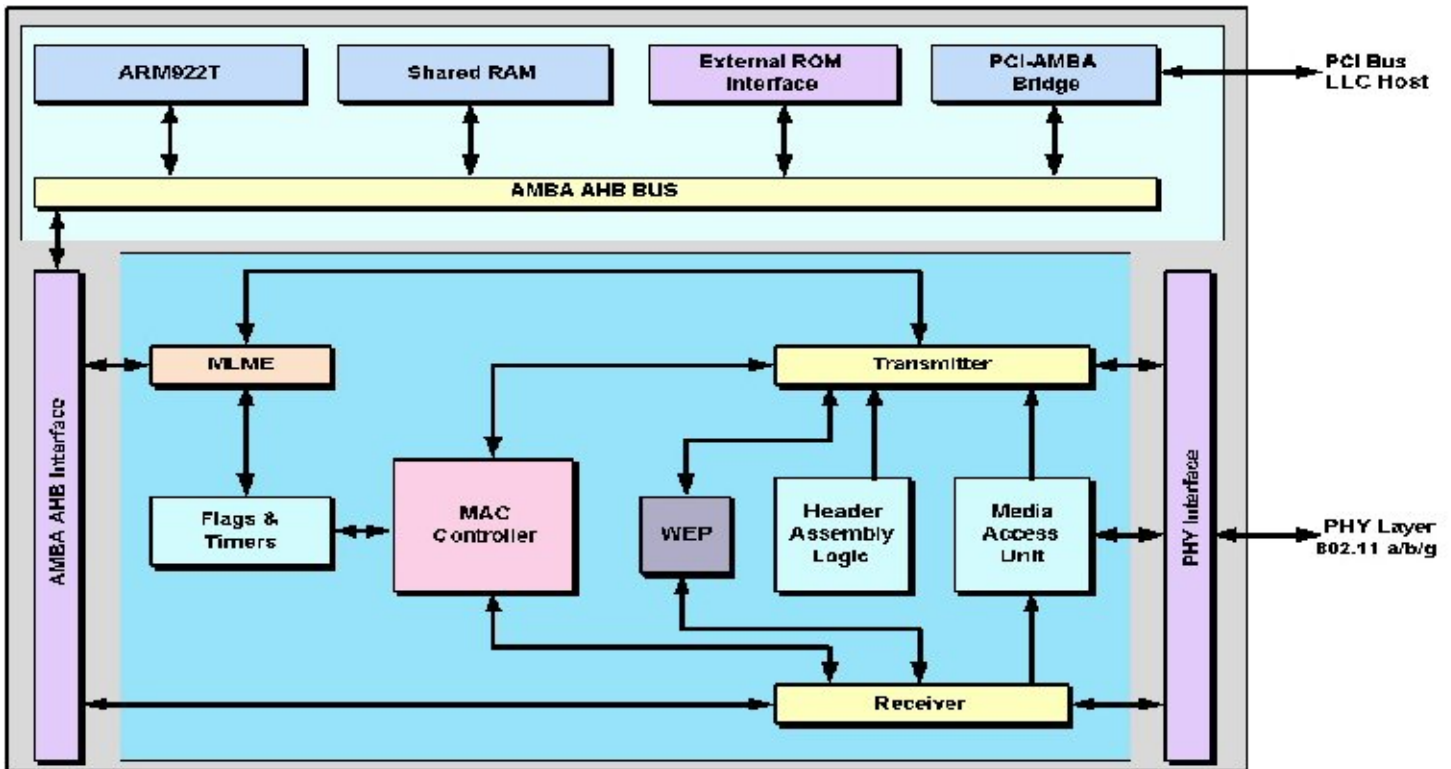

SI24WLAN11 MAC based on SoC design, supports ARM922T processor for Management Level Functionality to address the needs of complex design system, low power consumption and high performance. A shared RAM shall be used for the management operations done by the ARM processor. The AMBA AHB architecture is used for transferring management operations to the ARM processor and the data to the Host Layer through PCI-AMBA Bridge.

Brief description of MAC Modules:

MAC: Centrally controls the MAC operation. Takes the decision of which packet to be transmitted next. Interacts with MAU, Transmitter, Receiver and HAU for the MAC operations to be performed.

MLME: MAC Layer Management Entity controls all the management related activities.

HAU: Header Assembly Unit prepares the Header of the Packet as indicated by the MAC.

MAU: Implements CSMA/CA and Distributed Algorithm Function (DCF) to sense the medium.

Flags and Timers: Contains the Status Flags and Timers used to watch the management activities.

Transmitter: Transmits the frame by sequentially arranging the Packet Fields and appending it with CRC bytes.

Receiver: Receives the packet by checking the Destination Address and diverts the management packets and data packets.

PHY Interface: The Frames are passed and received from the PHY Layer to the MAC Layer.

AMBA AHB Interface: The Frames from the MAC Layer are transferred to the AMBA AHB Bus through the Interface.

Contact:

Email: info@siliconinterfaces.com

Phone: (+91-22) 2491 3024; Fax: (+91-22) 2498 1379

In USA: (+1-408) 866 2458; Fax: (+1-408) 866 6586

In UK: (+44-20) 8543 4436; Fax: (+44-20) 8544 1311

Notice: Information in this document is indicative. Product specifications are subject to change without notice. Silicon Interfaces shall not be responsible for direct, indirect or consequential damages that may accrue through typographical errors or otherwise. No license, expressed or implied to any intellectual property rights is granted by this document. Product names mentioned herein may be trademarks and/or registered trademarks of their respective owners. Rights are hereby acknowledged.

Silicon Interfaces®
a software and vlsi design center

Silicon Interfaces is the world's answer to integrated solutions for Design Services needs for SOC, ASIC & FPGA for Wireless, Cable & Optical Networking, Fiber Channel & Inter-connect, Data Communications and Storage. Silicon Interfaces is operating since 1990 primarily in USA, Europe and Pacific Rim.